

THE REPRODUCTION, DISTRIBUTION AND UTILIZATION OF THIS DOCUMENT, AS WELL AS THE COMMUNICATION OF ITS CONTENTS TO OTHERS WITHOUT EXPLICIT AUTHORIZATION IS PROHIBITED. OFFENDERS WILL BE HELD LIABLE FOR THE PAYMENT OF DAMAGES. ALL RIGHTS RESERVED IN THE EVENT OF THE GRANT OF A PATENT, UTILITY MODEL OR DESIGN. (PER ISO 15016)

REVISIONS			
REV	DESCRIPTION	DATE	APPROVED
A	INITIAL RELEASE SUPERSEDES PRE-PRODUCTION DRAWING FJ5985-1012S REV "NONE" (1) ADDED "(2 REQUIRED)" (2) 4.24 REF WAS 4.30 REF (3) 2.67 REF WAS 2.72 REF	1999-06-08	EN-F19170 DP-1256 JJB

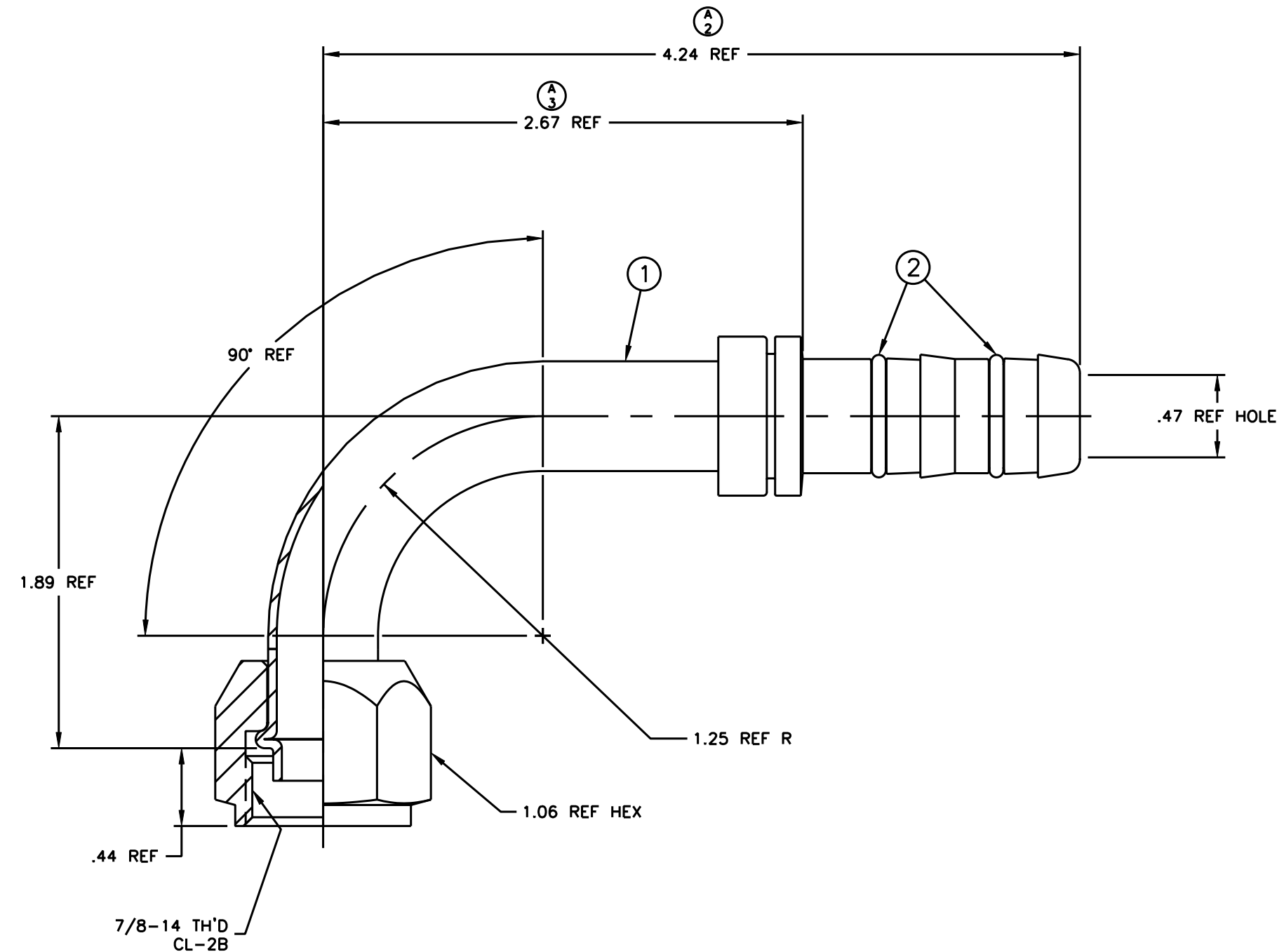

FN

REV. A
SH. *

INCH

ITEM NO.	MATERIAL	QTY	DESCRIPTION
1	STEEL	1	NIPPLE ASSEMBLY
2	HNBR	2	O-RING

FJ5985-1012S	FJ4985-1012S	1F40106-12	
AEROQUIP PART NUMBER	NIPPLE ASSEMBLY	O-RING (2 REQUIRED)	

DRAWN T. HARTFORD			
CHECKED J. BAHNSEN			
APPROVED J. GRAU			
RELEASE DATE 1999-08-25			
EN-F19170 DP-1256			
THIRD ANGLE PROJECTION			
ITEM TYPE: DTZA			

FLUID CONVEYANCE DIVISION			
DRAWING TITLE: FITTING ASSEMBLY			
90°, FEMALE O-RING PILOT (SHORT), GH134 HOSE			
SIZE A2	DRAWING NUMBER FJ5985-1012S	REV A	
SCALE 2/1	DIST U	CAGE CODE 01276	SHEET NO *

1. PROCESS AS FOLLOWS:
(a) LUBRICATE O-RINGS AND ASSEMBLE ON NIPPLE AS SHOWN.

DWG. NO. FJ5985-1012S

