

REVISIONS			
REV	DESCRIPTION	DATE	APPROVED
A	1) ADDED NEW PART NO. "FCE4324"	2020-08-24 AAG	CO-0207135
B	1) FBE4324 WAS FCE4324.	2020-09-29 AAG	CO-0208943

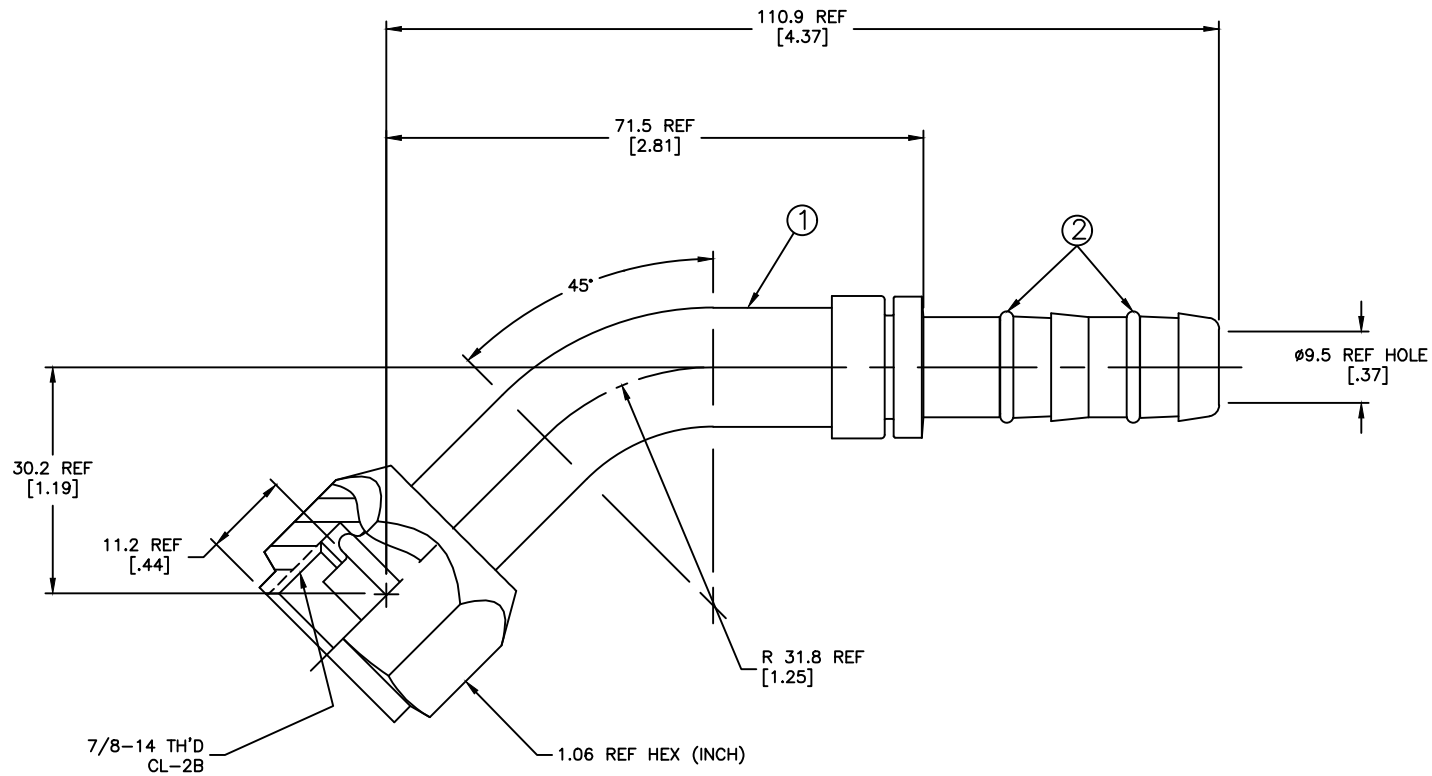

METRIC

- 2. DIMENSIONS ARE IN MILLIMETERS [INCHES].
- 1. LUBRICATE O'RINGS AND ASSEMBLE TO NIPPLE AS SHOWN.

FBE4324	FJ3055-05-1010S	FJ2055-05-1010S	1F40106-10		
HIGH PERFORMANCE PART NUMBER	PART NUMBER	① NIPPLE ASSEMBLY	② O'RING (2 REQ'D)		
LIST OF MATERIALS					
ITEM NO.	MATERIAL	DRAWN: W.R.HYDE CHECKED: R.D.GARRETT APPROVED: R.D.GARRETT RELEASE DATE: 1999-12-19 EN-F19520 DP-1256 THIRD ANGLE PROJECTION			
1	STEEL	FLUID CONVEYANCE DIVISION DRAWING TITLE: FITTING ASSEMBLY 45°, FEMALE O'RING PILOT (SHORT), GH134 HOSE SIZE: A2 DRAWING NUMBER: FJ3055-05-1010S REV: B SCALE: 2/1 DIST: U CAGE CODE: 01276 SHEET: 1			
2	HNBR				
THE REPRODUCTION, DISTRIBUTION AND UTILIZATION OF THIS DOCUMENT AS WELL AS THE COMMUNICATION OF ITS CONTENTS TO OTHERS WITHOUT EXPLICIT AUTHORIZATION IS PROHIBITED. OFFENDERS WILL BE HELD LIABLE FOR THE PAYMENT OF DAMAGES. ALL RIGHTS RESERVED IN THE EVENT OF THE GRANT OF A PATENT, UTILITY MODEL OR DESIGN. (PER ISO 18016)					