

REV	DESCRIPTION	BY	CHK	DATE	ECN
A	RELEASE FOR SAMPLES AND ESTIMATE	EMR	JED	2-11-98	M18898A
B	ENGINEERING RELEASE	EMR	JED	3-5-98	32571
C	SCHEMATIC ERROR	BMS	MJZ	6-6-00	36089

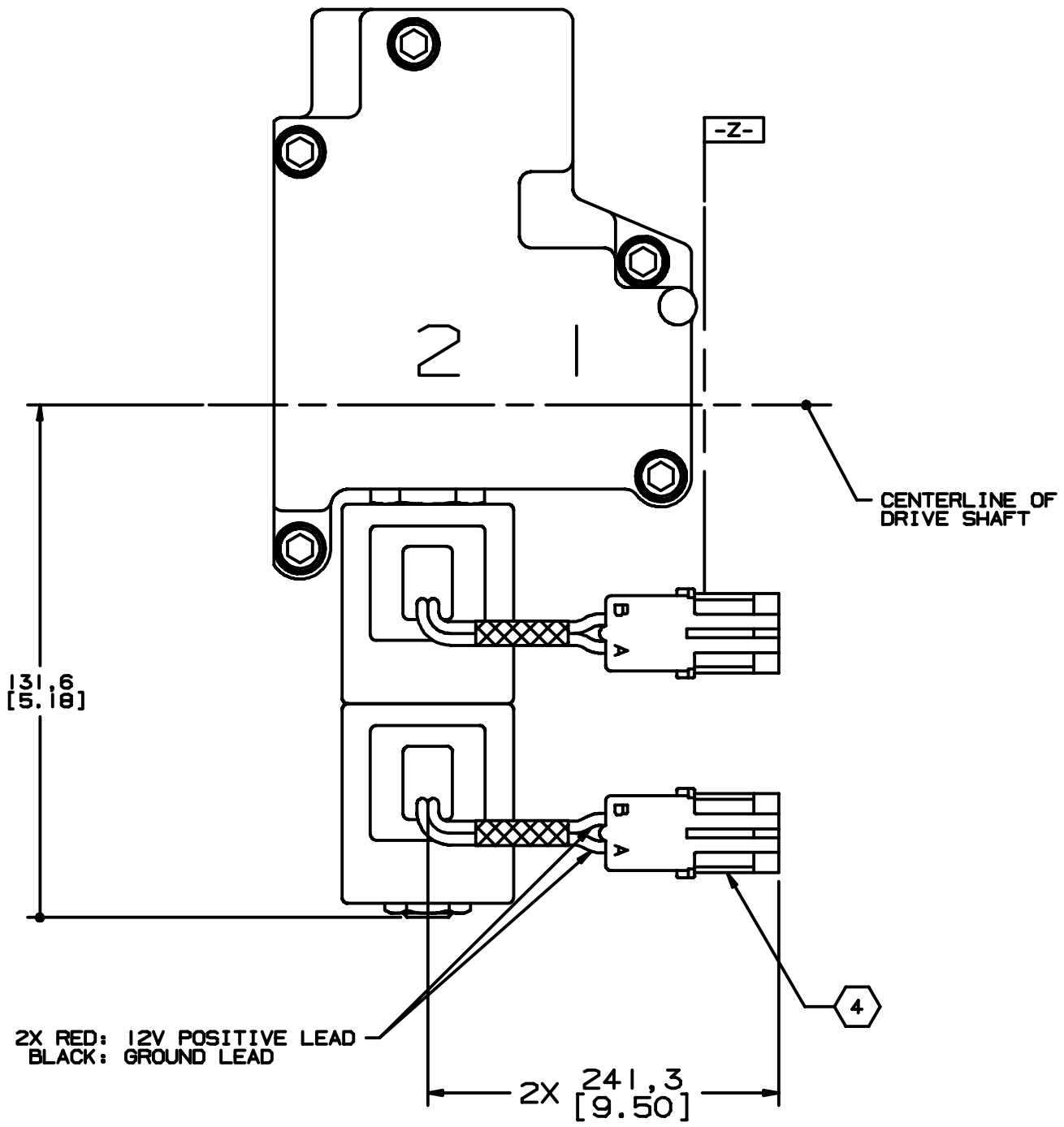
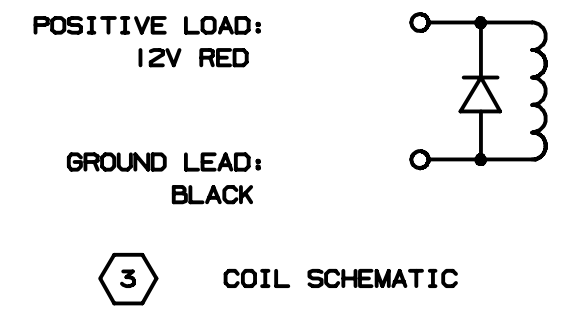
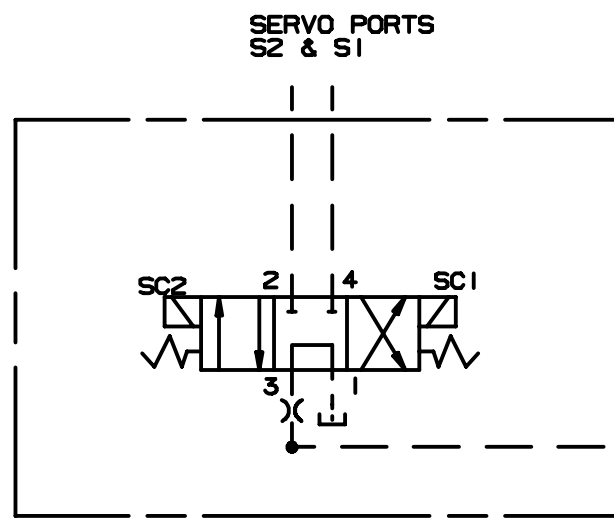
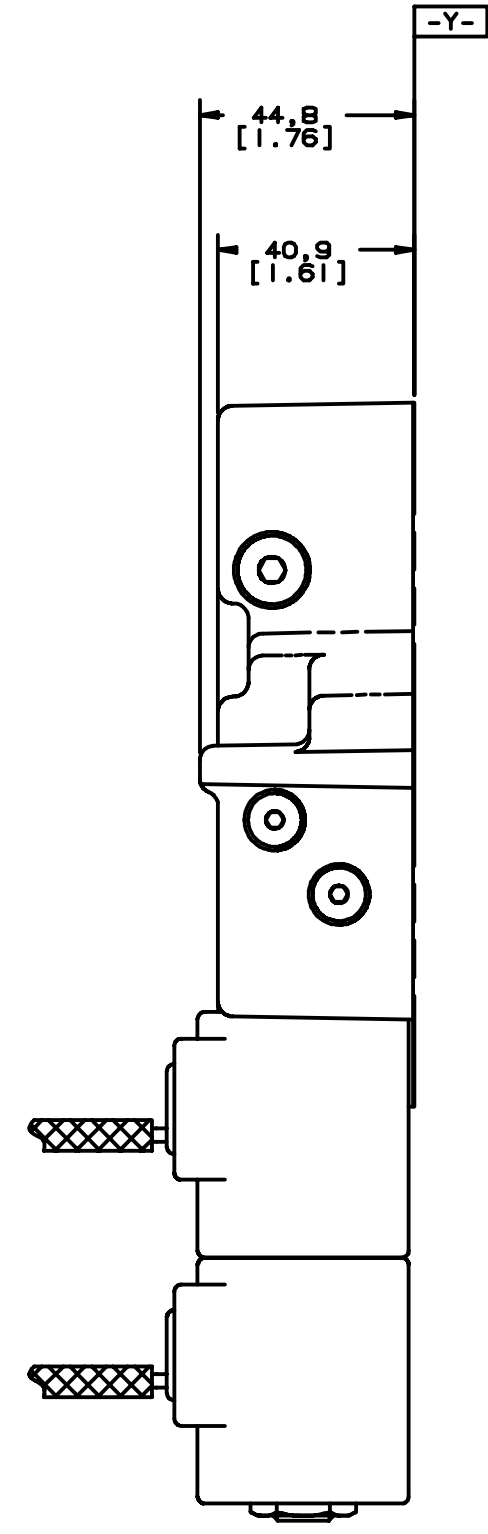
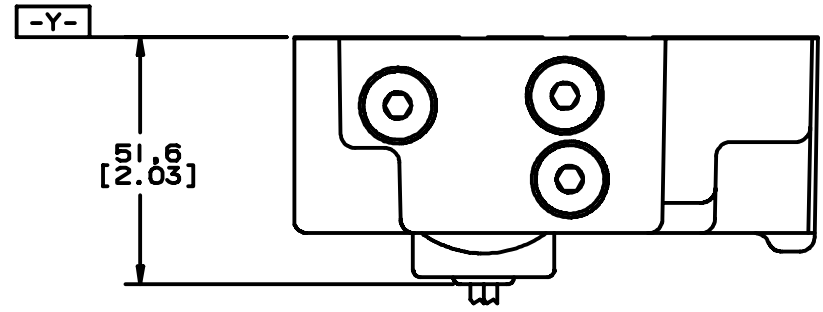

- NOTE
- 1 UNLESS OTHERWISE SPECIFIED ALL DIMENSIONS ARE NOMINAL
  - 2 COILS ARE 12 VDC, 9.8 OHMS AT 20°C, 1.22 AMPS INITIAL CURRENT DRAW.
  - 3 COILS HAVE SCHEMATIC CONFIGURATION
  - 4 MATING CONNECTORS 2X CONNECTOR • 1201 5792 (BLACK)  
 TERMINAL • 1208 9188 (2)  
 SEAL • 1201 5323 (2)

UNLESS OTHERWISE SPECIFIED ALL DIMENSIONS ARE IN INCHES <input type="checkbox"/> MILLIMETERS (DIMES)	DRAWING BASED ON ANSI Y14.5M-1982		
	THE REPRODUCTION, DISTRIBUTION, AND UTILIZATION OF THIS DOCUMENT, AS WELL AS THE COMMUNICATION OF ITS CONTENTS TO OTHERS WITHOUT EXPLICIT AUTHORIZATION IS PROHIBITED. OFFENDERS WILL BE HELD LIABLE FOR THE PAYMENT OF DAMAGES. ALL RIGHTS RESERVED IN THE EVENT OF THE GRANT OF A PATENT, UTILITY MODEL, OR DESIGN. (PER ISO 16016)		
TOLERANCES .X A --- .XX A --- .XXX A --- < A ---	DATE: EMR 3-20-98 DATE: JED 4-23-98 DATE: JI 4-28-98	MATERIAL/HWY TREAT FILE FORWARD-NEUTRAL-REVERSE CONTROL	
UNSPECIFIED RADES ARE --- UNSPECIFIED DRAFT ANGLES ARE --- DRAWING FORMALLY CHECKED BY: [initials]	THIRD ANGLE PROJECTION DO NOT SCALE	NUMBER A-994-025 SCALE 1/1 SHEET 1 OF 1	