

REV	DESCRIPTION	BY	CHK	DATE	ECN / MPS
A	ENGINEERING RELEASE	JGS	AH	2/12/05	M63978
B	ADDED SYMBOL	VR	IK	08-25-11	M81045A
C	UPDATED HYDRAULIC SYMBOLS IN A-2416-107 DRAWING	MBK	YKP	09/24/15	0113337

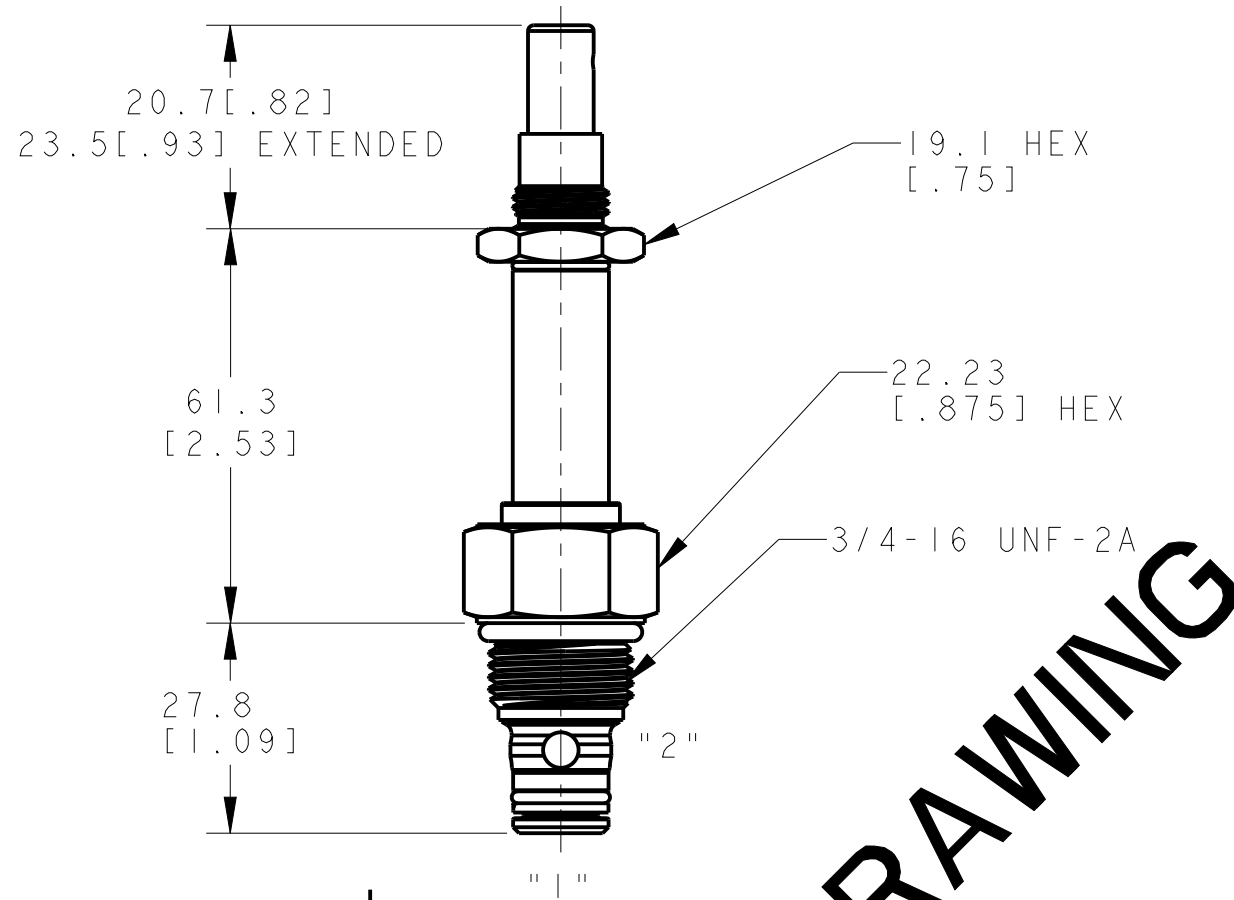

A-2416-107

NOTE:

- 1 USE VALVE CAVITY: C-8-2
- 2 NET WEIGHT:  
 CARTRIDGE: .10 kg [.21 lb]  
 CARTRIDGE W/COIL: .28 kg [.62 lb]  
 CARTRIDGE W/COIL AND ALUMINUM BODY: .46 kg [1.02 lb]
- 3 TORQUE INTO CAVITY:  
 ALUMINUM CAVITY: 34-41 N.m [25-30 lbf.ft]  
 STEEL CAVITY 34-41 N.m [25-30 lbf.ft]

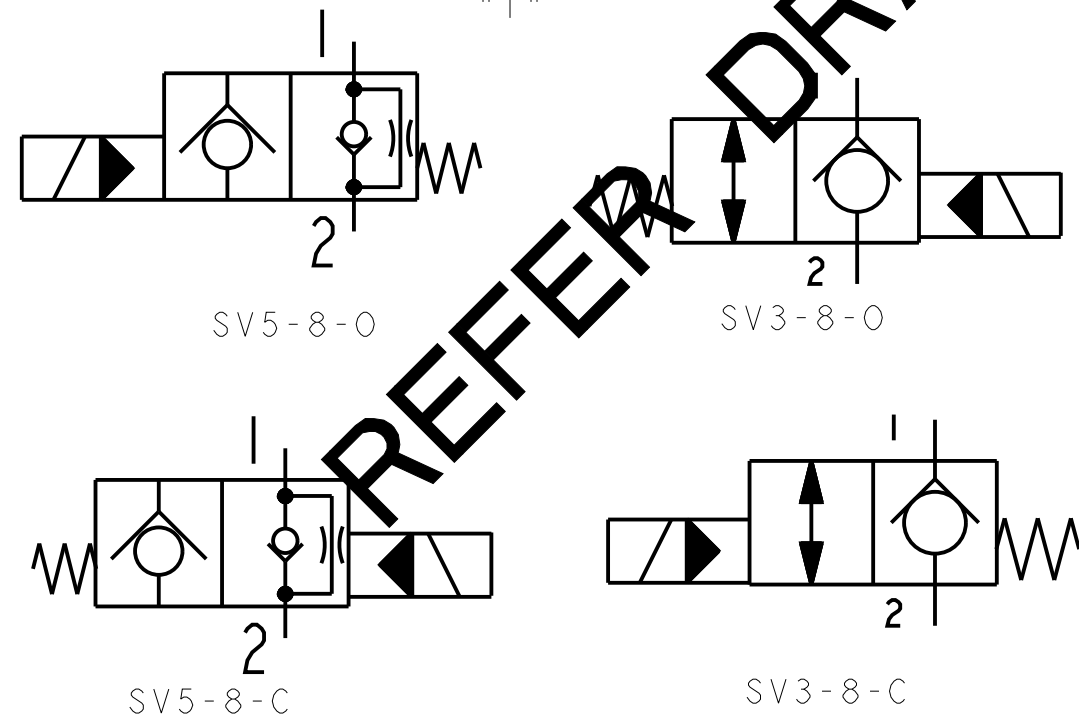

REFER DRAWING

UNLESS OTHERWISE SPECIFIED ALL DIMENSIONS ARE IN INCHES <input type="checkbox"/> MILLIMETERS (INCHES) <input checked="" type="checkbox"/>	DRAWING BASED ON ANSI Y14.5M-1982	
	THE REPRODUCTION, DISTRIBUTION, AND UTILIZATION OF THIS DOCUMENT, AS WELL AS THE COMMUNICATION OF ITS CONTENTS TO OTHERS WITHOUT EXPLICIT AUTHORIZATION IS PROHIBITED. OFFENDERS WILL BE HELD LIABLE FOR THE PAYMENT OF DAMAGES. ALL RIGHTS RESERVED IN THE EVENT OF THE GRANT OF A PATENT, UTILITY MODEL, OR DESIGN. (PER ISO 16016)	
TOLERANCES .X ± .XX ± .XXX ± ∠ ±	DRAWN JGS BY/DATE 12/6/04	MATERIAL/HEAT TREAT \
UNSPECIFIED RADII ARE: ----	CHECKED LMD BY/DATE 1/10/05	TITLE SOLENOID VALVE INSTALLATION
UNSPECIFIED DRAFT ANGLES ARE: -----°	ENGRG NF BY/DATE 1/10/05	NUMBER A-2416-020
B SIZE	METALLURGY BY/DATE \	SCALE 1/1
	THIRD ANGLE PROJECTION DO NOT SCALE	SHEET 1 OF 1
	ARITHMETICAL AVERAGE <input checked="" type="checkbox"/>	

