

REVISIONS			
REV	DESCRIPTION	DATE	APPROVED
E	REDRAWN - SUPERSEDES 1SA_FJA_REV. "D" FOR 1SA4FJA4 (1) WAS 10.2 REF	10-9-95	EN-F16023 DP-24900
F	(1) REMOVED PROCESS AS FOLLOWS NOTE. (2) ADDED NOTE. (3) ADDED NOTES AND FLAGGED. (4) "404501-4S" WAS "1F40017-04-01AB" (5) "45.1 REF [1.78]" WAS "49.7 REF" (6) "21.7±0.8 [.85±.031]" WAS "26.3±0.8"	2005-08-31 RR	EN-F29243 DP-1299
G	(1) TOLERANCE ±1.5 [±.060] WAS ±0.8 [±.031]	2007-10-11 PSW/ADN	0006849 -ECO
H	(1) CORRECTED FONT SIZE FOR NOTE SECTION (2) ADDED DIAMETER SYMBOL	2019-10-31 VVS	CO-0194961
J	1) FINISH WAS "ZINC PLATE PER ES 2751".	2020-06-01 DMK	CO-0203715

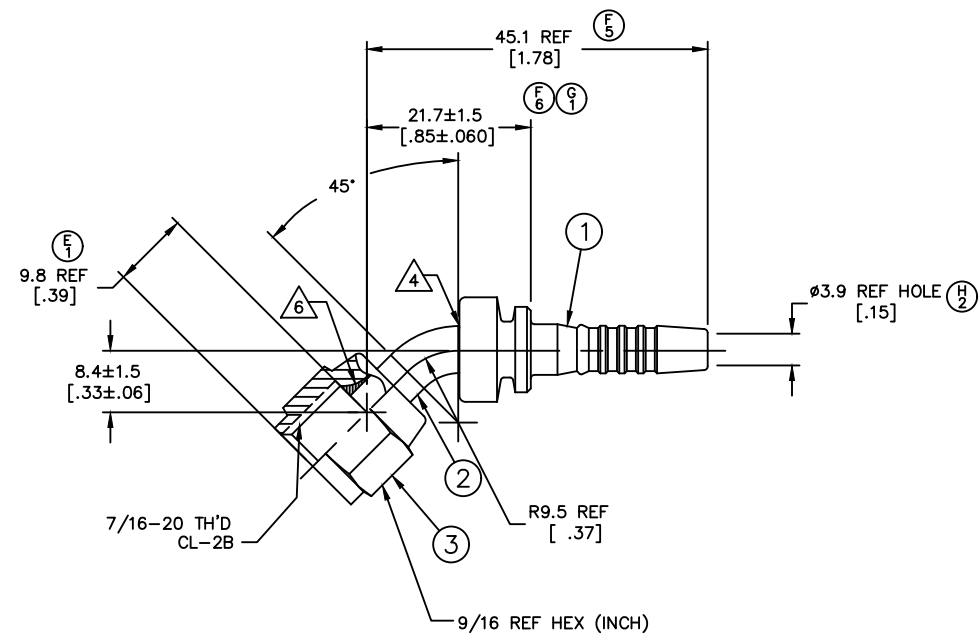

METRIC

- ①
- ② CAN BE MADE FROM TUBING PER SPECIFICATIONS ON ELBOW DRAWING.
- ③ DIMENSIONS ARE IN MILLIMETERS [INCHES].
- ④
- ⑤ ZINC PLATE PER ES 2751D8.
- ⑥ FORM PER FF481.
- ⑦

⑤	1SA4FJA4	1F40014-0404AB	404501-4S	210221-4S		
	PART NUMBER	① NIPPLE	② ELBOW	③ NUT		
LIST OF MATERIALS						
ITEM NO.	MATERIAL	DRAWN K. PADGETT		FLUID CONVEYANCE DIVISION		
1	STEEL	CHECKED R. GARRETT				
2	STEEL	APPROVED R. GARRETT		DRAWING TITLE		
3	STEEL	RELEASE DATE 10-12-95		NIPPLE ASSEMBLY		
		EN-F16023		45° SAE 37° SWIVEL, 2781 HOSE		
		DP-24900		SIZE	DRAWING NUMBER	REV
		THIRD ANGLE PROJECTION		A2	1SA4FJA4	J
		SCALE	DIST	CAGE CODE	SHEET	
		2/1	U	01276	1	

THE REPRODUCTION, DISTRIBUTION AND UTILIZATION OF THIS DOCUMENT AS WELL AS THE COMMUNICATION OF ITS CONTENTS TO OTHERS WITHOUT EXPLICIT AUTHORIZATION IS PROHIBITED. OFFENDERS WILL BE HELD LIABLE FOR THE PAYMENT OF DAMAGES. ALL RIGHT RESERVED IN THE EVENT OF THE GRANT OF A PATENT, UTILITY MODEL OR DESIGN. (PER ISO 16016)