

REVISIONS			
REV	DESCRIPTION	DATE	APPROVED
K	REDRAWN - SUPERSEDES 1SA_FRB-SHEET 2 REV."J" FOR 1SA20FRB20	11-3-95	EN-F16053 DP-24900
L	1) NOTE #1(b) WAS ZINC PLATE PER ACES 2751	2020-06-18 ARK	CO-0204147

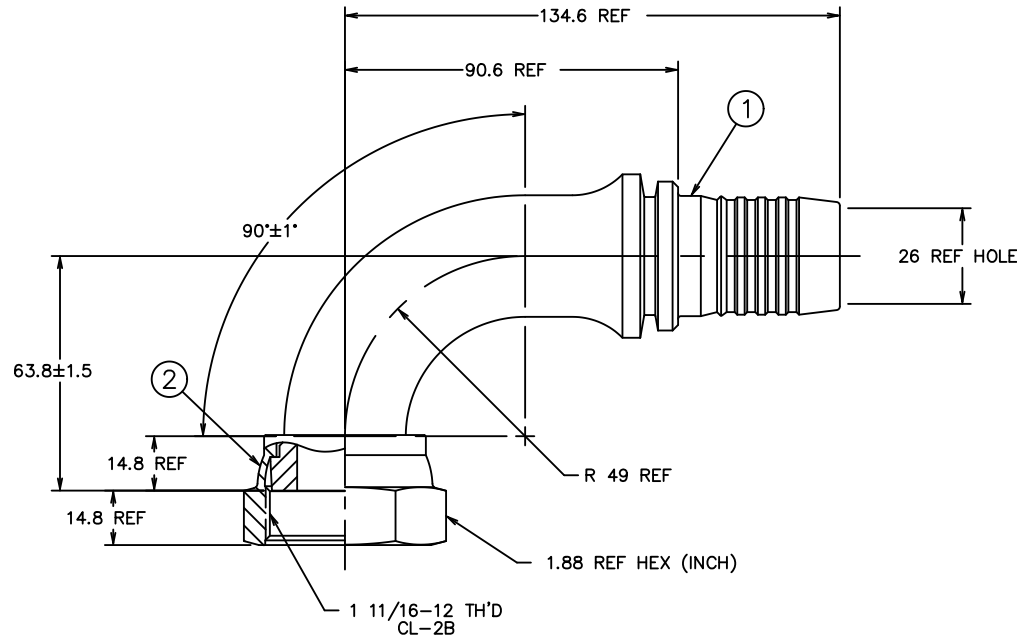

134.6	5.30
90.6	3.57
63.8±1.5	2.51±.06
49	1.93
26	1.02
14.8	.58
MM	INCH

CONVERSION

METRIC

1SA20FRB20	1F40023-2020AB	FC1473-20S			
AEROQUIP PART NUMBER	① NIPPLE	② NUT			
LIST OF MATERIALS					
ITEM NO.	MATERIAL	DRAWN R.D. GARRETT	FLUID CONVEYANCE DIVISION DRAWING TITLE NIPPLE ASSEMBLY 90°, ORS FEMALE SWIVEL 2781 HOSE		
1	STEEL	CHECKED M. MOLINA			
2	STEEL	APPROVED R.D. GARRETT			
		RELEASE DATE 1995-11-07			
		EN-F16053	SIZE A2	DRAWING NUMBER 1SA20FRB20	REV L
		DP-24900	SCALE 1/1	DIST U	CAGE CODE 01276
		THIRD ANGLE PROJECTION			SHEET 1
THE REPRODUCTION, DISTRIBUTION AND UTILIZATION OF THIS DOCUMENT AS WELL AS THE COMMUNICATION OF ITS CONTENTS TO OTHERS WITHOUT EXPLICIT AUTHORIZATION IS PROHIBITED. OFFENDERS WILL BE HELD LIABLE FOR THE PAYMENT OF DAMAGES. ALL RIGHT RESERVED IN THE EVENT OF THE GRANT OF A PATENT, UTILITY MODEL OR DESIGN. (PER ISO 18016)					

1. PROCESS AS FOLLOWS:
 (a) BEND NIPPLE TO DIMENSIONS SHOWN.
 (b) ZINC PLATE PER ES 2751DB.
 (c) CRIMP NUT PER ACES 2409P1. ①